

Quarch Technology Ltd

Torridon Multiprotocol Breaker

Technical Manual

For use with:

QTL2602 – Multiprotocol Breaker Module

Using Quarch firmware 5.000, FPGA 1.1 and above

Monday, 30 May 2022



Change History

1.0	20 th September 2021	Initial Release
1.1	1 st March 2022	Updated PSU voltage ranges and added threshold commands information.
1.2	30 th May 2022	Added appendix 4 to include information on supported protocols.

Contents

Quarch Technology Ltd	1
Torridon Multiprotocol Breaker	1
Technical Manual	1
Change History	2
Introduction	5
Product Safety	6
Safety warnings.....	6
Additional notes.....	6
Technical Specifications	7
Switching Characteristics:	7
Mechanical Characteristics:	7
Control Interfaces	7
Basic Concepts	8
Signal Configuration.....	11
Power Up vs. Power Down Timing.....	13
Pin Bounce Modes	14
Constant Oscillation Frequency	14
User Pin-Bounce (Custom Oscillation)	16
Glitch Control	19
Glitch Once.....	19
Glitch Cycle.....	20
Glitch PRBS.....	21
Signal Driving.....	22
Signal Monitoring.....	23
Requesting signal state	23
Live monitoring	24
Voltage Measurements.....	25
Default Startup State	25
Controlling the Module	27



Terminal Command Set	27
Appendix 1 - Signal Names	38
Appendix 2 – Signals supporting ‘Monitoring’	39
Appendix 3 – Support for Quarch Power Studio	40
Appendix 4 – Supported Protocols.....	40

Introduction

The **Torridon Multiprotocol Breaker Module** allows remote switching of both power supply and data signals in a communication link. This is ideal for automotive serial links and similar scenarios, where testing of link interruption is critical for safety testing.

A wide range of power and signaling voltages are supported, along with communication links up to 700MHz speed.

Links can be plugged/pulled by simple command, and short 'glitches' can be inserted down to 50nS.

Signals passing through the unit can be monitored by polling from a script. The unit is also compatible with QPS (Quarch Power Studio), where you can see the link status and digital signaling in real time.

Product Safety

This product is intended for experienced technical users in a test lab environment. It is able to stress/damage devices under test, so it is essential that you are familiar with this manual and the device operation before use.

Safety warnings

This product must be connected to an appropriate 12v DC, 0.8A supply. We recommend using the 12v PSU supplied with the product. Other supplies can be used but should be appropriately rated and IEC tested to LPS-PS2 or better

Additional notes

- The product is certified for use with Ambient temperatures up to 40C

Technical Specifications

Switching Characteristics:

Screw Terminals	Description	Switching Action
Ground	Ground Pin	Always connected
Power	Link Power	Switched by power FET
Signal 1-4	Link Data	Switched by analog switch

Mechanical Characteristics:

The module is an external desk unit, 95mm by 135mm by 35mm in size.

Pluggable terminal blocks are used for rapid connection into a wiring loom.

Control Interfaces

The breaker module is based on the 'Torridon' standards and operates the same as out other Breaker modules. It does NOT have an 8-pin Torridon cable though and instead is operated as a 'standalone' module.

It does not require a separate controller, and can be directly connected via USB or LAN.

Basic Concepts

Each controlled pin is connected to a separate switch on the module, so it can be connected or isolated on command.

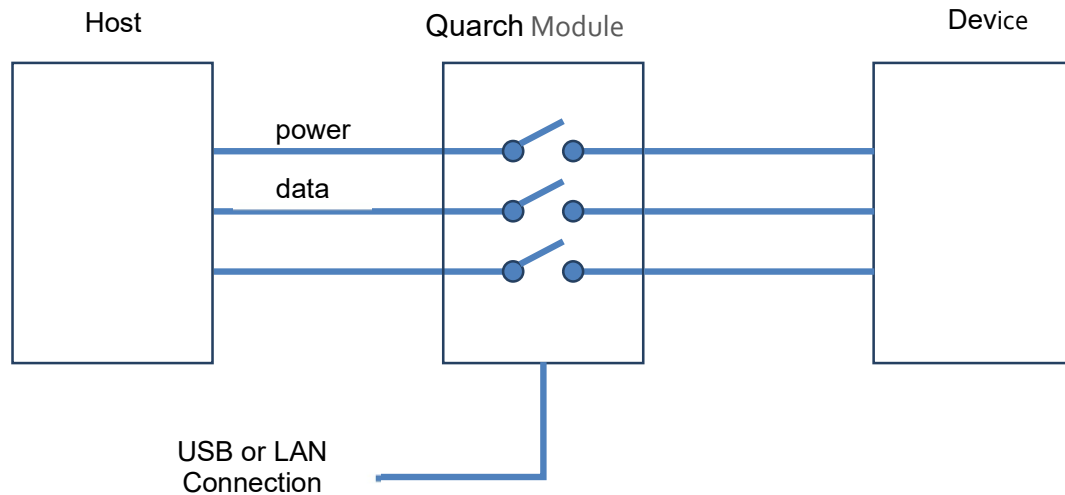

Each switch on the module is called a 'Signal' and can be programmed to follow one of six programmable delay and bounce profiles (called 'Sources'). This allows the user to sequence the signal connections in the cable in up to six programmable steps.

This allows us to create virtually any hot-swap scenario. The default scenario on the module is based on the pin lengths on the connector, so that the long pins mate first, followed by shorter pins.

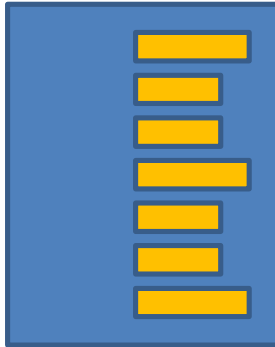

Each of the programmable delay and bounce profiles is called a control source, S1 to S6. For each control source the user sets up a delay, and bounce parameters. Three special sources (S0, S7 and S8) are also provided as described in the table below.

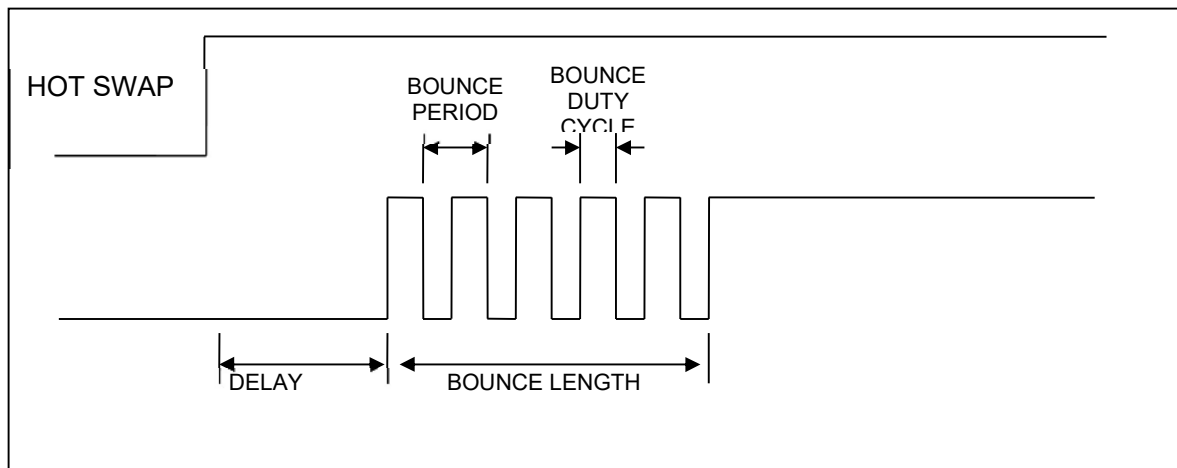

Control Source Parameters for a power up event (Basic Pin Bounce)

Once each delay period is set up, the user assigns each signal to follow the relevant control source, then uses the “**run:power up**” and “**run:power down**” commands to initiate the hot-swap.

The BUSY bit 1 in the control register is set during a power up, power down and short operation. This may be used to monitor for the completion of timed events.

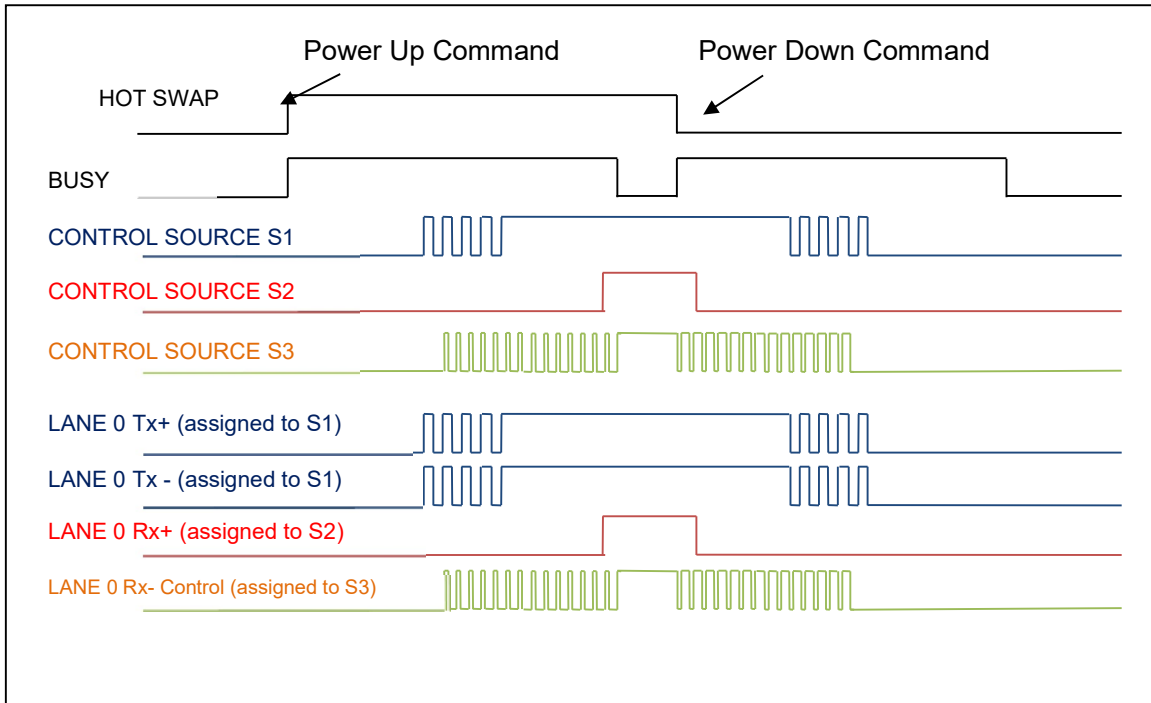

Power up and Power down example

Signal Configuration

Each signal that is switched by the module is usually assigned to one of the 6 timed sources, S1 – S6. Each signal can also be assigned directly to 'always off' (source 0), 'immediate change' (source 7) or 'Always on' (source 8).

Signals assignment is done through the command:

SIGnal:[name]:SOURce [Source#]

Source Number	Description
0	Signal is always OFF
1	Signal assigned to control source 1
2	Signal assigned to control source 2
3	Signal assigned to control source 3
4	Signal assigned to control source 4
5	Signal assigned to control source 5
6	Signal assigned to control source 6
7	Signal changes with HOT_SWAP state
8	Signal is always ON

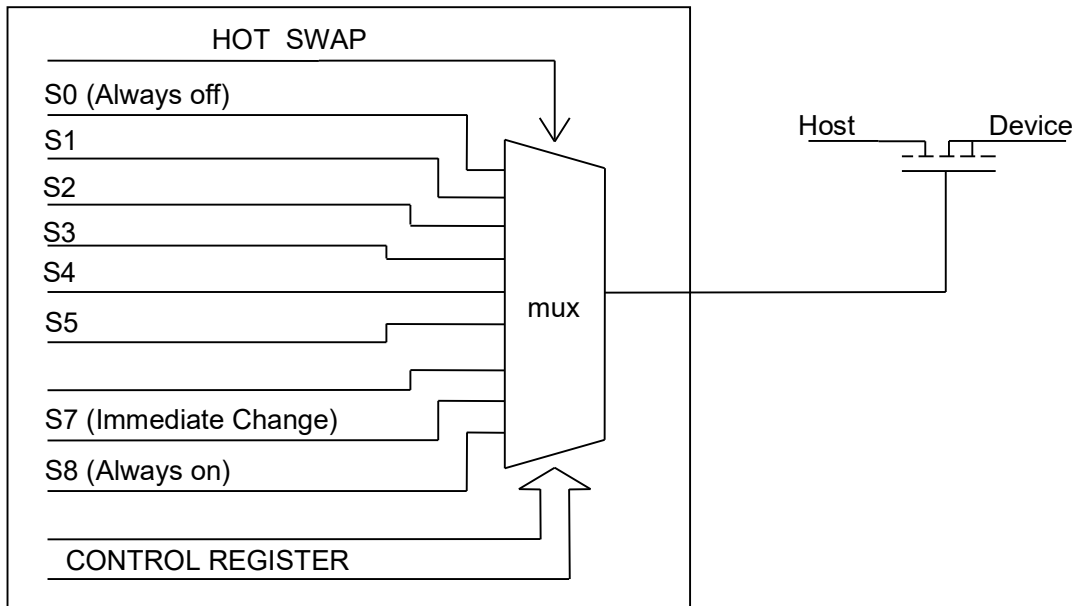

This diagram shows the 9 possible source settings entering the control MUX for a switched signal. The value of the control register will determine which of the sources are used to control the signal. When enabled, the hot-swap line will cause the MUX to pass the control signal from that source through to the switch.

Power Up vs. Power Down Timing

Each control source is always configured with power-up parameters. The power-down profile is automatically generated by the module, and is the mirror image of the power up:

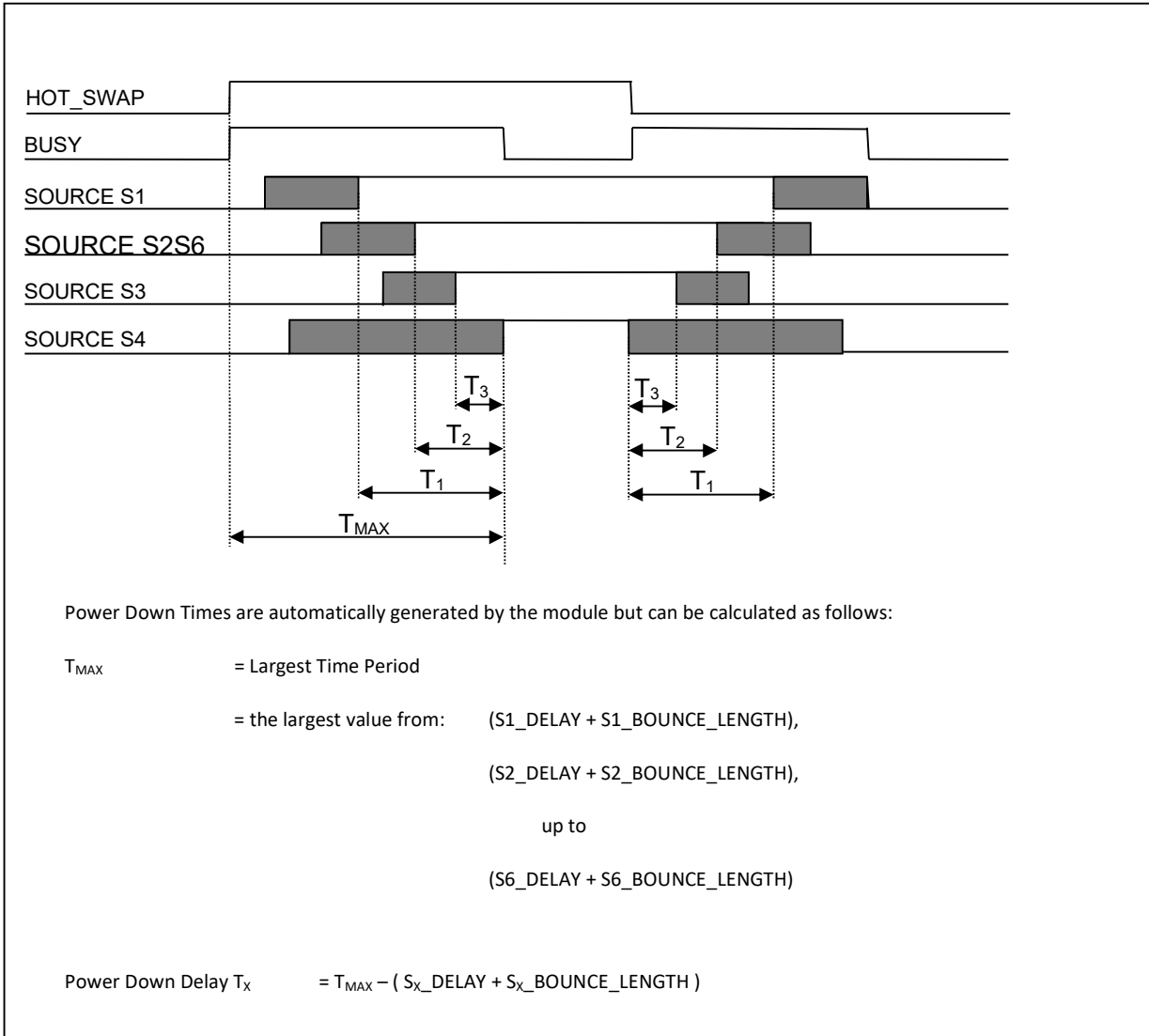

If you require a different power down sequence then you can alter any of the source timing values, pin bounce or signal assignments while the module is in the plugged state. When you initiate the 'pull' action, the new settings will be used.

Pin Bounce Modes

Pin Bounce can be set in two ways:

Constant Oscillation Frequency

- For **basic** firmware the Oscillation Time is set in one of two ranges:
 - ▣ 0-127 milliseconds in steps of 1mS
 - ▣ 0-1.27 seconds in steps of 10mS
- For **high-resolution** firmware the Oscillation Time is set in one range:
 - ▣ 0-16,777,215uS, in steps on 1uS
 - ▣ Commands default to mS resolution but the user can add another unit as an additional parameter

- For **basic** firmware the Oscillation Period is for the pattern is set in one of two ranges:
 - ▣ 0-1.27 milliseconds in steps of 10uS
 - ▣ 0-127 milliseconds in steps of 1mS
- For **high-resolution** firmware the Oscillation Period is set in one range:
 - ▣ 0-1,677,721,500nS, in steps on 100nS
 - ▣ Commands default to uS resolution but the user can add another unit as an additional parameter

The Duty cycle (On %) is set as a percentage value in the range 0-100%.

A value of 0% would leave the source off for the duration of the Oscillation Time.

A value of 50% provides a symmetrical square wave as shown below and is the default.

A value of 100% would turn the signal on for the duration of Oscillation Time.

Basic bounce behavior on power up

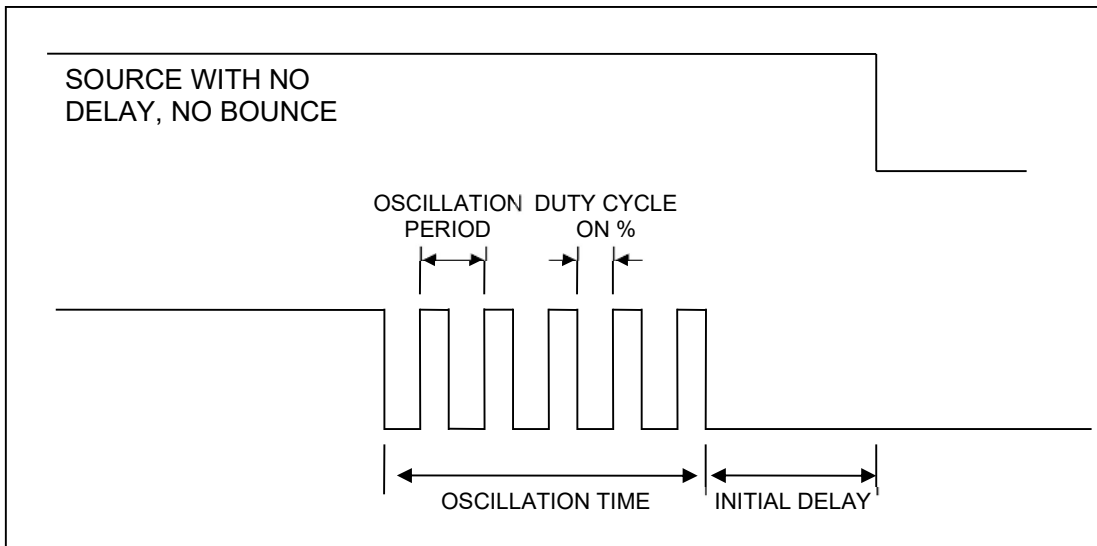
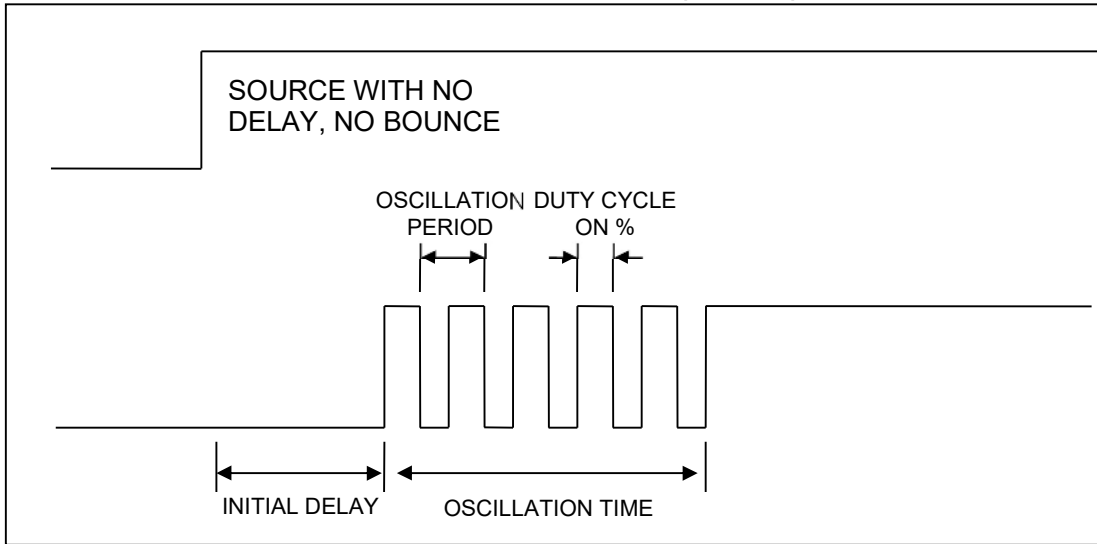

Basic bounce behavior on power down

User Pin-Bounce (Custom Oscillation)

User Pin bounce allows the user to set a custom pattern of up to 112 bits which will be executed by the module instead of standard pin bounce. A custom pattern of alternating 1's and 0's would create a square wave just like the default basic bounce mode.

The executed pattern is determined by a number of factors:

- For **basic** firmware the Oscillation Time is set in one of two ranges:
 - 0-127 milliseconds in steps of 1mS
 - 0-1.27 seconds in steps of 10mS
- For **high-resolution** firmware the Oscillation Time is set in one range:
 - 0-16,777,215uS, in steps on 1uS
 - Commands default to mS resolution but the user can add another unit as an additional parameter
- For **basic** firmware the Oscillation Period is for the pattern is set in one of two ranges:
 - 0-1.27 milliseconds in steps of 10uS
 - 0-127 milliseconds in steps of 1mS
- For **high-resolution** firmware the Oscillation Period is set in one range:
 - 0-1,677,721,500nS, in steps on 100nS
 - Commands default to uS resolution but the user can add another unit as an additional parameter
- The Pattern length may be set:
 - 1-112 bits
 - Choose to repeat pattern or sit on last bit until the end of Oscillation Time.

Custom Patterns can get confusing very quickly, the best way to make sure that the power down sequence is the opposite of power up, is to make sure that:

(Bit length * Number of Bits = Oscillation Time)

so that the pattern ends exactly at the end of Oscillation time. The

SOURce:[x]:BOUNce:PATtern:SETup command does this automatically.

Custom patterns run in reverse on a power down, please see the following diagrams for examples of the same pattern being run on a power up and power down situation.

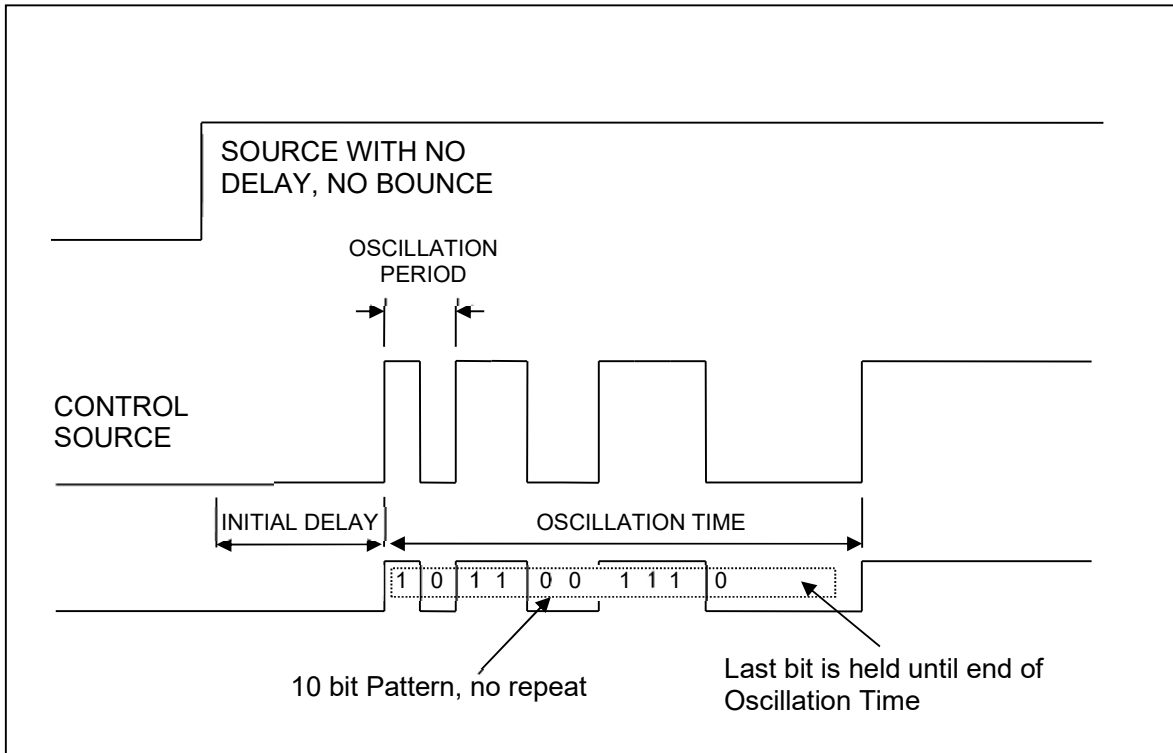

User bounce behavior on power up

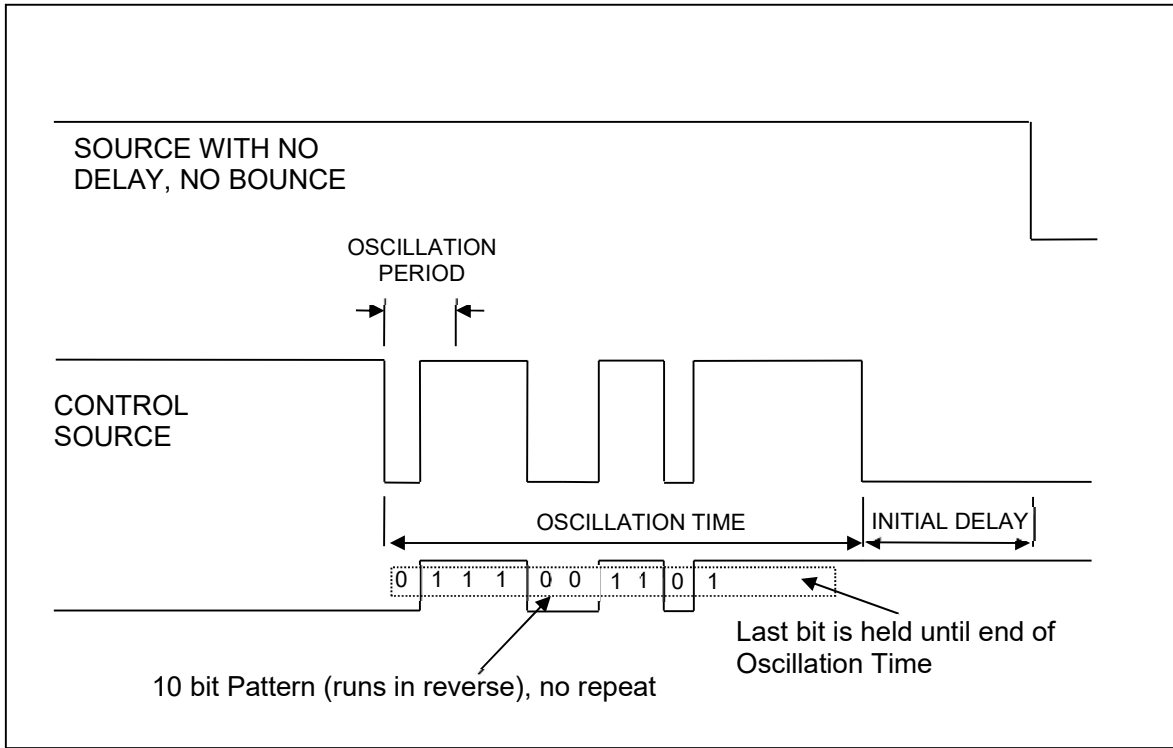

User bounce behavior on power down

Glitch Control

Any control signal may be glitched for a pre-determined length of time using the glitch generator logic.

Each Signal Control register contains a “**GLITCH:ENABLE**” bit which determines whether the glitch logic will affect that signal. The setting, defaults to off, so any glitches will have no effect unless explicitly set to do so.

Glitches will invert the current state of the switched signal. Therefore if a switch is currently OFF, a glitch will turn it ON, and if the switch is ON, it will turn OFF.

For modules that support signal driving, the glitch action will drive the signal following the ‘**DRIVE:OPEN**’ and ‘**DRIVE:CLOSED**’ settings

Glitches may be applied in 3 modes:

Glitch Once

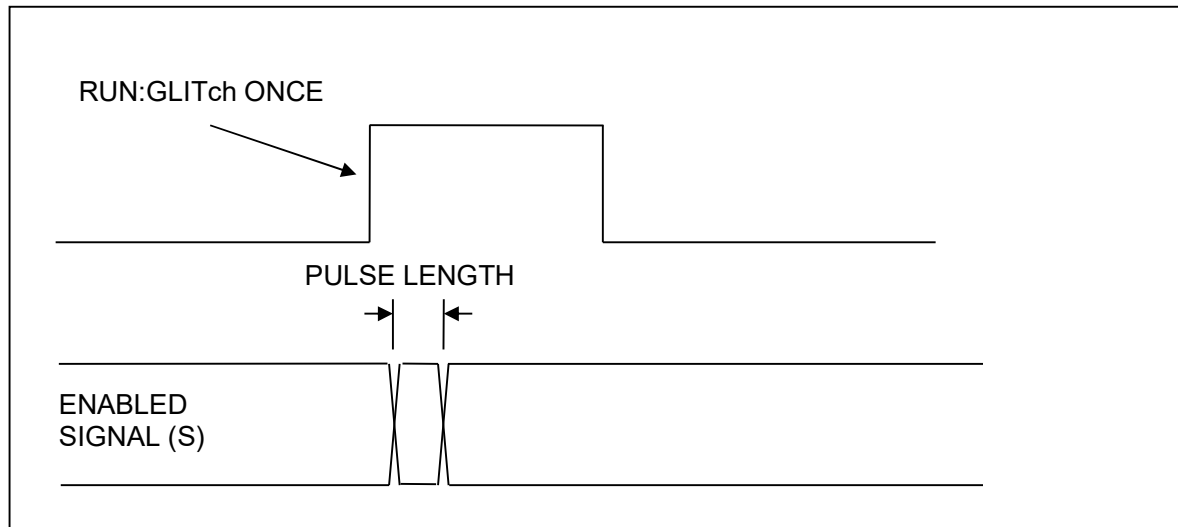

A single glitch is generated when the **RUN:GLITCh ONCE** command is executed.

The length of the glitch is determined by using the **GLITCh:SETup** command or the **GLITCh:MULTiplier** and **GLITCh:LENGth** commands:

$$\text{PULSE LENGTH} = \text{GLITCh:MULTiplier} \times \text{GLITCh:LENGth}$$

Repeated use of the **RUN:GLITCh:ONCE** command will generate multiple glitches, it is not necessary to use the **RUN:GLITCh OFF** command after a single glitch.

Glitch Cycle

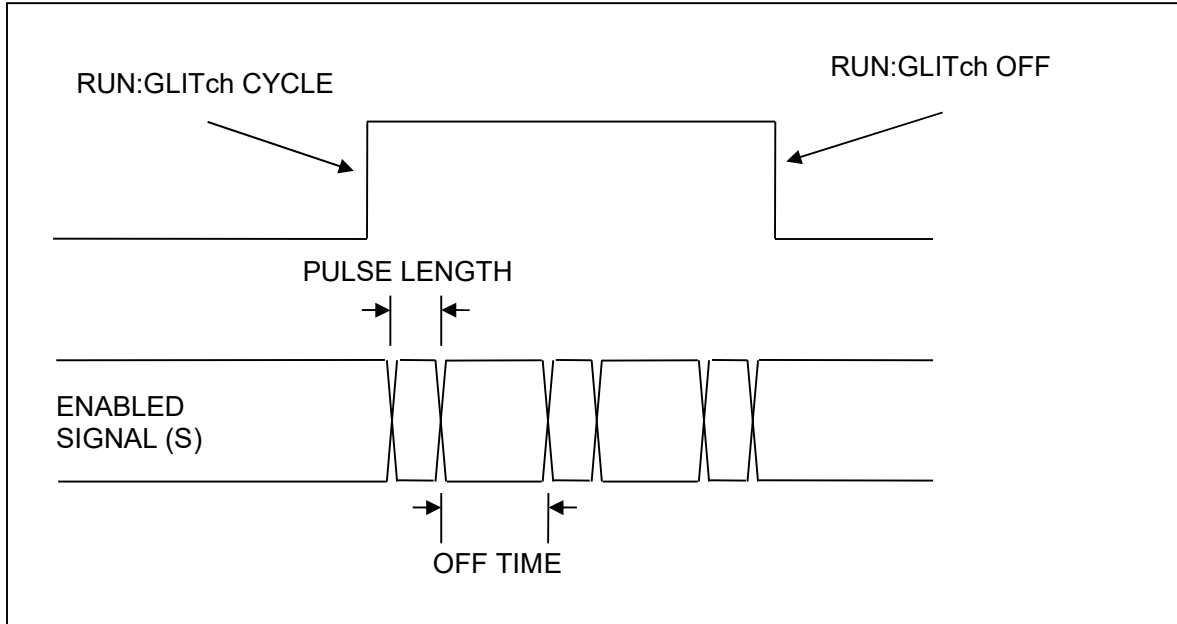

A sequence of glitches is generated when the **RUN:GLITCh CYCLE** command is executed, and continues until **RUN:GLITCh OFF** is executed.

The length of the glitch is determined by using the **GLITCh:SETup** command or the **GLITCh:MULTiplier** and **GLITCh:LENGth** commands:

$$\text{PULSE LENGTH} = \text{GLITCh:MULTiplier} \times \text{GLITCh:LENGth}$$

The length of time between each glitch pulse is set in the same way as the glitch length, The length of the gap is determined by using the **GLITCh:CYClE:SETup** command or the **GLITCh:CYClE:MULTiplier** and **GLITCh:CYClE:LENGth** commands:

$$\text{OFF TIME} = \text{GLITCh:CYClE:MULTiplier} \times \text{GLITCh:CYClE:LENGth}$$

Glitch PRBS

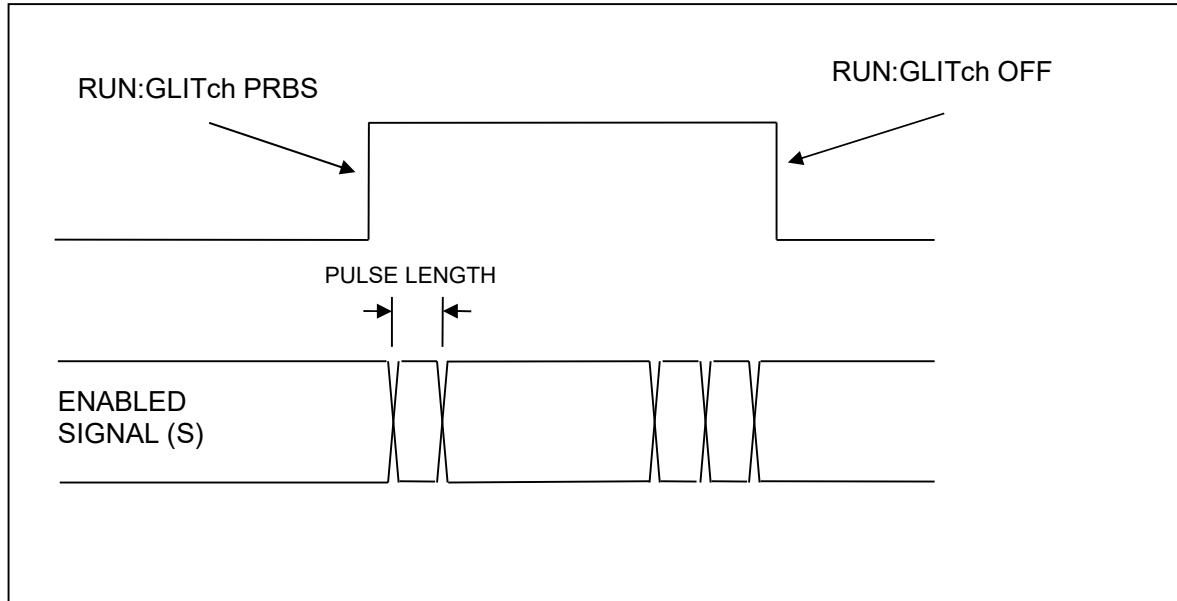

A pseudo random sequence of glitches is generated when the **RUN:GLITCh PRBS** command is executed, and continues until **RUN:GLITCh OFF** is executed.

The length of the glitch is determined by using the **GLITCh:SETup** command or the **GLITCh:MULTiplier** and **GLITCh:LENGTh** commands:

$$\text{PULSE LENGTH} = \text{GLITCh:MULTiplier} \times \text{GLITCh:LENGTh}$$

The number of glitches in a set length of time is determined by the **GLITCh:PRBS** command. A value of 2 will result in glitches at a ratio of 1:2 (the line will be in a glitched state 50% of the time), whilst a value of 256 will produce glitches in a ratio of 1:256.



Signal Driving

This module does not currently support signal driving

Signal Monitoring

The 'signal monitoring' feature allows specific signals on a module (normally sideband signals) to be tracked.

The state of a monitored signal can be requested from the module at any time via a command. On 'triggering' modules, the state of a signal can be output in real time to one of the triggering ports. As there are two trigger ports, two signals can be monitored at a time. This is ideal for diverting SM_BUS to an analyser.

For a list of signals on the module that support triggering, see the annex at the end of the manual.

Requesting signal state

To get the state of a monitored signal:

SIGna1 : [SIGNAL -NAME] : STATus : [HOST? | DEViCe?]

Returns the current state of the monitored signal as **HIGH** or **LOW**. The signal state can (if supported) be monitored independently on both the host and device side of the module.

Live monitoring

This feature is supported on 'Triggering' modules only. Both the trigger IN and OUT ports can be used to monitor a signal.

WARNING: As the trigger IN port can be ordered to OUTPUT a status, there is a risk of two devices driving against each other and causing damage. Before using the live monitoring feature, you must ensure that you do not have any equipment attached that may try to drive the trigger IN port.

To begin live monitoring, first enable the trigger ports you want to use. This is done via additional options to the existing trigger setup commands:

Trigger OUT port:

```
# Set the trigger mode to sideband monitor
```

```
TRIGger:OUT:MODE:SIDEband
```

Trigger IN port (requires double verification)

```
# Set the trigger mode to sideband monitor
```

```
TRIGger:IN:MODE:SIDEband
```

```
# Also set the trigger IN source to sideband out
```

```
TRIGger:IN:SOURCE:SIDEband
```

The commands to control monitoring are:

```
# Select a signal for live monitoring
```

```
TRIGger:MONitor[IN|OUT]:[SIGNAL-NAME]:[HOST|DEVICE]
```

Sets a trigger port to activate live monitoring for a given signal. The host/device parameter selects the side of the module to monitor on.

```
TRIGger:MONitor[IN?|OUT?]
```

Returns the selection for live monitoring on the given trigger port. The response will be in the form **PERST:HOST** or similar (**SIGNAL_NAME:SIDE**)

Note that the triggering mode must also be set before the live monitoring will start.

Voltage Measurements

The modules are capable of measuring various voltages both for self test and to assist in the testing of a customer’s system. The following measurement points are available:

Measurement Command	Description	Resolution / Accuracy
MEASure:VOLTage:SELF 1v2?	Returns the voltage of the modules internal 1.2v rail	46mV / 3%
MEASure:VOLTage:SELF 3v3?	Returns the voltage of the modules internal 3v3 power rail	46mV / 3%
MEASure:VOLTage:SELF 5V?	Returns the voltage of the modules internal 5v power rail	46mV / 3%
MEASure:VOLTage host?	Returns the host side of the power rail	46mV / 3%
MEASure:VOLTage device?	Returns the device side of the power rail	46mV / 3%

Default Startup State

On power up or reset, the control modules enter a default state. To make the module as easy to use as possible, the default state is a ‘standard’ hot-swap scenario with preset source and signal settings such that the “run:power up” command will immediately power up the drive without needing any initial setup.

The default hot-swap scenario will connect pre-charge then power then pins, each step with a 25mS delay. All sources are enabled.

Source Number	Source Enabled	Initial Delay
1	YES	0mS
2	YES	0mS
3	YES	0mS
4	YES	0mS
5	YES	0mS
6	YES	0mS

Signal	Assigned Source
--------	-----------------



All signals	Source 1
-------------	----------

Hot-Swap State:

Drive is in the 'plugged' state, waiting for a **"RUN:POWER DOWN"** command to remove it.

Controlling the Module

The module can be controlled either by:

- Serial ASCII terminal (such as HyperTerminal)
This is normally used with scripted commands to automate a series of tests. The commands are normally generated by a script or user code (PERL, TCL, C, C# or similar).
- Telnet Terminal (Only when connected to an Array Controller).
This mode uses exactly the same commands as the serial ASCII terminal, but run over a standard Telnet connection.
- REST API (Only when connected to an Array Controller).
Controllers provide a basic REST API, allowing multi-user control over Torridon products.
- USB
Quarch's TestMonkey application can control a single module via USB, this allows simple graphical control of the module. The Quarch C# API and Python examples allow automation via USB.

Terminal Command Set

These commands are based on the SCPI style control system that is used by many manufacturers of test instruments. The entire SCPI specification has NOT been implemented but the command structure will be very familiar to anyone who has used it before.

- SCPI commands are NOT case sensitive
- SCPI commands are in a hierarchy separated by ':'
(**LEVe11:LEVe12:LEVe13**)
- Most words have a short form (e.g. '**register**' shortens to '**reg**'). This will be documented as **REGister**, where the short form is shown in capitals.
- Some commands take parameters. These are separated by spaces after the main part of the command (e.g. "**meas:volt:self 3v3?**" obtains the 3v3 self test measurement).
- Query commands that return a value all have a '?' on the end
- Commands with a preceding '*' are basic control commands, found on all devices.
- Commands that do not return a particular value will return "**OK**" or "**FAIL**". Unless disabled, the fail response will also append a text description for the failure if it can be determined.

[comments]

Any line beginning with a # character is ignored as a comment. This allows commenting of scripts for use with the module.

***RST**

Triggers a reset, the module will behave as if it had just been powered on.

***CLR**

Clear the terminal window and displays the normal start screen. Also runs the internal self test. The same action can be performed by pressing return on a blank line.

***IDN?**

Displays a standard set of information, identifying the device. An example return is shown below:

Family:	Torridon System	[The parent family of the device]
Name:	Ethernet Cable Pull Module	[The name of the device]
Part#:	QTL1271-01	[The part number of the hardware]
Processor:	QTL1159-01, 3.50	[Part# and version of firmware]
Bootloader:	QTL1170-01, 1.00	[Part# and version of bootloader]
FPGA 1:	1.0	[Version of FPGA core]

***TST?**

Runs a set of standard tests to confirm the device is operating correctly, these tests are also performed at start up. Returns 'OK' or 'FAIL' followed by a list of errors that occurred, each on a new line.

CONFig:MODE BOOT

Configures the card for boot loader mode (to update the firmware), requires an update utility on the PC.

CONFig:MESSAgES [SHORT|USER]

CONFig:MESSages?

Gets or sets the mode for messages that are returned to the user's terminal

Short: Only a "FAIL" or "OK" will be returned.

User: Full error messages are returned to the user on failure.

CONFig:TERMinal USER

Sets the terminal response mode to the default 'User' setting. This is intended for use with HyperTerminal or similar and manually typed commands.

CONFig:TERMinal SCRIPT

Sets the terminal response mode for easier parsing. Especially useful from a UNIX/LINUX based system. Characters sent from the PC are not echoed by the device and a <CR><LF> is sent after the cursor to force a flush of the USART buffer.

CONFig:TERMinal?

Returns the current terminal mode.

CONFig:DEFault STATE

Resets the state of the module. This will set all source/signal/glitch etc logic to its default power-on values. Terminal setting will not be affected. This command allows the module to be brought back to a known state without resetting it.

MEASure:VOLTage [12vin?|12vout?|12vin_chg?|12vout_chg?|3v3in_aux?|3v3out_aux?]

Returns the voltage on the specified rail in mV. Vin refers to the upstream or host side of the card, and Vout refers to the switched, drive side. Values are returned in the form "3300mV".

MEAS:VOLTage:SELF [3v3?,5v?,-5v?]

Returns the self test voltages. These are measurements of voltage rails required for correct operation of the module. The values are returned in the form "5000mV"

SOURce:[1-6|ALL]:SETup [#1] [#2] [#3] [#4]

Sets up the source in a single command. All parameters are positive integer numbers:

#1 = Initial delay (mS)

[Limits: 0 to 127ms in steps of 1ms, 0 to 1270ms in steps of 10ms]

#2 = Bounce length (mS)

[Limits: 0 to 127ms in steps of 1ms, 0 to 1270ms in steps of 10ms]

#3 = Bounce Period (uS)

[Limits: 10 to 1270us in steps of 10us, 1000 to 127000us in steps of 1000us]

#4 = Duty Cycle (%)

[Limits: 0 to 100% in steps of 1%]

SOURce:[1-6|ALL]:DELAY [#ms] [#Unit*]

SOURce:[1-6|ALL]:DELAY?

Sets the initial delay of a source in mS. The delay is entered as a integer number with no units. E.g. "Source:1:delay 300".

#1 = Initial delay (mS)

[Limits: 0 to 127ms in steps of 1ms, 0 to 1270ms in steps of 10ms]

#2 = Optional unit specifier (High resolution firmware only) [uS, mS, S]. High resolution firmware allows initial delay of 0 to 16,775mS in 1uS resolution.

This parameter is optional, to be back-compatible with older firmware

SOURce:[1-6|ALL]:BOUNce:SETup [#1] [#2] [#3]

Sets up the bounce parameters in a single command. All parameters are positive integer numbers:

#1 = Bounce length (mS)

[Limits: 0 to 127ms in steps of 1ms, 0 to 1270ms in steps of 10ms]

#2 = Bounce Period (uS)

[Limits: 10 to 1270us in steps of 10us, 1000 to 127000us in steps of 1000us]

#3 = Duty Cycle (%)

[Limits: 0 to 100% in steps of 1%]

SOURce:[1-6|ALL]:BOUNce:LENgth [#ms] [#Unit*]

SOURce:[1-6|ALL]:BOUNce:LENgth?

Sets the length of the pin bounce in mS. The delay is entered as a decimal number with no units. E.g. "Sour:2:boun:len 50".

#1 = Bounce length (mS)

[Limits: 0 to 127ms in steps of 1ms, 0 to 1270ms in steps of 10ms]

#2 = Optional unit specifier (High resolution firmware only) [uS, mS, S]. High resolution firmware allows initial delay of 0 to 16,775mS in 1uS resolution.

This parameter is optional, to be back-compatible with older firmware

SOURce:[1-6|ALL]:BOUNce:PERiod [#us] [#Unit*]

SOURce:[1-6|ALL]:BOUNce:PERiod?

Sets the bounce period of the pin bounce in uS. The value is entered as a decimal number with no units. E.g. “**Sour:6:boun:period 300**”.

#1 = Bounce Period (uS)

[Limits: 10 to 1270us in steps of 10us, 1000 to 127000us in steps of 1000us]

#2 = Optional unit specifier (High resolution firmware only) [uS, mS, S]. High resolution firmware allows initial delay of 0 to 1,677mS in 100nS resolution.

This parameter is optional, to be back-compatible with older firmware

SOURce:[1-6|ALL]:BOUNce:DUTY [#%]

SOURce:[1-6|ALL]:BOUNce:DUTY?

Sets the duty cycle of the pin bounce as a %. The value is entered as a decimal number with no units. E.g. “**source:3:bounce:duty 50**”.

#1 = Duty Cycle (%)

[Limits: 0 to 100% in steps of 1%]

SOURce:[1-6|ALL]:BOUNce:MODE [SIMPLE|USER]

SOURce:[1-6|ALL]:BOUNce:MODE?

Sets the bounce pattern to **SIMPLE** (Duty cycle driven oscillation) or **USER** (User defined custom pattern).

SOURce:[1-6|ALL]:BOUNce:PATtern:WRITe [0xAAAA] [0xDDDD]

Writes a word of the custom bounce pattern to the give address within the pattern

0xAAAA is the address (for example 0x0002)

0xDDDD is the pattern data (for example 0x13F2)

SOURce:[1-6|ALL]:BOUNce:PATtern:READ [0xAAAA]

Reads a word of the custom bounce pattern

0xAAAA is the address (for example 0x0002)

SOURce:[1-6|ALL]:BOUNce:PATtern:DUMP [0xAAAA] [0xAAAA]

Reads a range of words from the custom bounce pattern

0xAAAA is the start and end address range (for example 0x0002)

SOURce:[1-6|ALL]:BOUNce:CLEAR

Removes any pin bounce from the source and sets all bounce settings to default values. See “Default Startup State” for details for the default settings.

SOURce:[1-6|ALL]:STATE [ON|OFF]**SOURce:[1-6|ALL]:STATE?**

Sets or returns the enable state of the source. Any signals assigned to a disabled (off) source will immediately be disconnected and vice versa. If a source state is changed, all signals assigned to it will change at exactly the same time (if a change is required).

SOURce:[1-6]:BOUNce:PATtern:LENgth [#bits]**SOURce:[1-6]:BOUNce:PATtern:LENgth?**

Sets or returns the number of bits of the custom bounce pattern that are to be used. This defaults to the maximum (112) and can be reduced to create more accurate patterns.

SOURce:[1-6]:BOUNce:PATtern:REPeat [ON|OFF]**SOURce:[1-6]:BOUNce:PATtern:REPeat?**

Sets the custom pattern repeat flag. This is used when the current custom bounce pattern is shorter than the specified bounce length. When the flag is set (default) the pattern will wrap. When this flag is off, the last bit of the pattern will be repeated.

SOURce:[1-6]:BOUNce:PATtern:SETup [#us] [#binarypattern]

Sets a basic custom pattern from a single command. This command will alter the bounce period, bounce length, pattern length and the custom pattern.

[#uS] – Integer value of uS to specify the period. The length of each bit in the pattern will be half of this value. 20uS is the minimum value (10uS per bit)

[#binarypattern] – String parameter containing 1s and 0s, for example “001” is a 2 bit pattern that is low for 2 bits then high for 1. The given pattern will always be padded up to the nearest millisecond. This is because the total glitch length has a 1mS resolution.

SIGnal:[SIG_NAME|ALL]:SETup [#num]

SIGnal:[SIG_NAME|ALL]:SOURce [#num]

Sets a given signal to a numbered timing source (0-8). SIGNAL_NAME is one of the items in the 'Signal Names' Appendix at the end of this manual.

SIGnal:[SIG_NAME]:SOURce?

Returns the source number that the signal is assigned to.

SIGnal:[SIG_NAME|ALL]:GLITch:ENABle [ON|OFF]

SIGnal:[SIG_NAME|ALL]:GLITch:ENABle?

Enables a signal for glitching. If this is on, the signal will be glitched whenever the glitch controller is in use. Multiple signals may be set for glitch at the same time.

RUN:POWer [UP|DOWN]

Initiates a plug or pull operation (legacy name used to preserve compatibility between Torridon modules). This is the master control for all switches on the card.

The command will fail if you order a power up when the module is already in the connected state and vice-versa as the action cannot be performed.

The "OK" response will be returned as soon as the hot-swap event has begun. If your timing sequence is very long you may have to poll the BUSY bit in register 0 to check when it has completed.

RUN:POWer?

Returns the current plugged/pulled state of the module.

RUN:GLITch ONCE

Triggers a single glitch with length:

GLITch:MULTIplier x GLITch:LENGth.

RUN:GLITch CYCLE

Triggers a sequence of repeated glitches that run until the **RUN:GLITch STOP** command is executed. All signals with **GLITch:ENABle** set to **ON** are glitched for **GLITch:MULTIplier x GLITch:LENGth** and then released for a duration of **GLITch:CYCLE:MULTIplier x GLITch:CYCLE:LENGth**. This is repeated until the **RUN:GLITch STOP** command is run.

RUN:GLITch PRBS

Triggers a PRBS glitch sequence which runs until the **RUN:GLITch STOP** command is issued.

RUN:GLITCh STOP

Stops any running glitch sequence.

RUN:GLITCh?

Returns the state of the current glitch sequence running on the module.

GLITCh:SETup [MULTIPLIER_STEP] [#count]

Sets up the length of the glitch in a single command.

#1 = Multiplier factor for glitch length (mS)

[50ns|500ns|5us|50us|500us|5ms|50ms|500ms]

#2 = Length of the glitch (number of times the multiplication factor will be run)

[Limits: 0 to 255 in steps of 1]

This gives a maximum glitch of 127.5 Seconds.

GLITCh:MULTIplier [MULTIPLIER_STEP]**GLITCh:MULTIplier?**

Sets the multiplier value for the glitch time to one of the specified durations.

This factor is multiplied with the **GLITCh:LENGth** value to give the actual glitch time.

#1 = Multiplier factor for glitch length (mS)

[50ns|500ns|5us|50us|500us|5ms|50ms|500ms]

GLITCh:LENGth [#count]**GLITCh:LENGth?**

This value is multiplied by **GLITCh:MULTIplier** to give the glitch duration.

#1 = Length of the glitch (number of times the multiplication factor will be run)

[Limits: 0 to 255 in steps of 1]

GLITch:CYCLE:SETup [MULTIPLIER_STEP] [#count]

Sets up the length of the glitch cycle in a single command.

#1 = Multiplier factor for glitch cycle length (mS)

[50ns|500ns|5us|50us|500us|5ms|50ms|500ms]

#2 = Length of the glitch cycle (number of times the multiplication factor will be run)

[Limits: 0 to 255 in steps of 1]

This gives a maximum glitch cycle time of 127.5 Seconds.

GLITch:CYCLE:MULTiplier [MULTIPLIER_STEP]**GLITch:CYCLE:MULTiplier?**

Sets the multiplier value for the glitch cycle time to one of the specified durations.

This factor is multiplied with the **GLITch:CYCLE:LENGth** value to give the actual time between cycled glitches.

#1 = Multiplier factor for glitch length (mS)

[50ns|500ns|5us|50us|500us|5ms|50ms|500ms]

GLITch:CYCLE:LENGth [#count]**GLITch:CYCLE:LENGth?**

This value is multiplied by **GLITch:CYCLE:MULTiplier** to give the actual time between cycled glitches.

#1 = Length of the glitch (number of times the multiplication factor will be run)

[Limits: 0 to 255 in steps of 1]

GLITch:PRBS [#1]

Sets the PRBS rate for Pseudo Random repeat glitching, this is a ratio, 2 means 1:2 (approximately 50% of the time the signal will be glitched), 256 means 1:256.

#1 = PRBS Ratio

[2|4|8|16|32|64|128|256|512|1024|2048|4096|8192|16384|32768|65536]

TRIGger:IN:TYPE [EDGE|LEVEL]

Sets the trigger type

EDGE = Actions will start on the asserted edge and complete in full

LEVEL = Actions will run for as long as the trigger signal is asserted

TRIGger:IN:INVERT [ON|OFF]

Sets the trigger invert mode for input triggers

OFF = Trigger acts as normal

ON = Trigger responds to an inverted input

TRIGger:OUT:INVERT [ON|OFF]

Sets the trigger invert mode for output trigger

OFF = Trigger acts as normal

ON = Trigger outputs in an inverted form

TRIGger:IN:SOURce [EXTErnal|???_host]

Sets the source of the trigger in event

EXTErnal = Uses the trigger in connector

???_host = Uses the output of the host power detect system. ??? is the voltage channel, generally 3v3_host or 12v_host, though the channel selection options will vary between modules.

TRIGger:IN:MODE [OFF|POWER|GLITCH]

Sets the action to perform on a trigger in event

OFF = No action (default mode)

POWER = Power cycle will be performed

GLITCH = Glitch action will be performed

TRIGger:OUT:MODE [OFF|POWER|GLITCH|???_host]

Sets the action to perform on a trigger out event

OFF = No action (default mode)

POWER = Trigger out shows power state

GLITCH = Trigger out on glitch

???_host = Trigger out on detect of host power. ??? is the voltage channel, generally 3v3_host or 12v_host, though the channel selection options will vary between modules.

Appendix 1 - Signal Names

The following signal names are used to specify a single signal or a group of signals. These may be used in commands that take a parameter "SIGNAL_NAME". Note that some commands, such as those returning a value, only accept a parameter that resolves to a single signal. In this case you cannot use the group names

Signals

POWER_SW

DATA_0_SW

DATA_1_SW

DATA_2_SW

DATA_3_SW

Signal Groups

ALL (Allows change of all signals at the same time)

Appendix 2 – Signals supporting ‘Monitoring’

Signal name	Monitor Names
POWER_SW	POWER_SW POWER_IN POWER_OUT
DATA_0_SW	DATA_0_SW DATA_0_IN DATA_0_OUT
DATA_1_SW	DATA_1_SW DATA_1_IN DATA_1_OUT
DATA_2_SW	DATA_2_SW DATA_2_IN DATA_2_OUT
DATA_3_SW	DATA_3_SW DATA_3_IN DATA_3_OUT

Each of the monitor points are controlled via a threshold value, which can be adjusted by the user. This provides support for a wide range of supply rail and digital signaling levels.

CONF:IN:D:[SIGNAL NAME]:THReshold:[#1]

Sets up the threshold value for selected signal (signal values above threshold will be read as ‘1’ and below the threshold as ‘0’).

#1 = Threshold value in millivolts (valid range -15000 to 15000, default set to 2400mV)

Appendix 3 – Support for Quarch Power Studio

This module is a hybrid design, containing our 'Breaker' features for hot-plug and fault injection, and support for display of the captured data in Quarch Power Studio (QPS).

QPS can display more than just power, it supports digital signals as well. The multi-protocol breaker can report on the real-time status of each monitored digital signal for capture and analysis.

This will allow you to track how your system responds to a plug/pull event, or even capture the bus transitions. Sampling for these signals is up to 250KHz.

Almost any Application Note or example that works without PAM (Power Analysis Modules) will work here, provided you remember that this product has no power measurement, only the digital values are supported.

As seen in Appendix 2, you can choose thresholds as required for your signal levels.

Appendix 4 – Supported Protocols

The following protocols are supported for switching (see note 1):

- USB-2
- RS-232
- RS-422
- RS-485
- CAN/LIN
- I2C
- 100Base-T1
- 1000Base-T1
- (See note 2)

Note 1: These protocols are supported for switching by the module, but monitoring will not support all protocol due to a maximum sample rate of 250KHz.

Note2: Other protocols may also be support that are not listed, if signal range is between -15V and 15V with a bandwidth of less than 460Mhz.