



M O D E L T O S 5 2 0 0

*An ideal AC Hipot Tester
with low cost of ownership
realized, built on more than
50 years of experience in market*



Hipot (Withstanding Voltage) Tester **AC Hipot Tester TOS5200**

- Highly-stable output with PWM Amp System
- 5 kV/100 mA (500 VA) AC Hipot test
- Short-circuit current 200 mA or more
- Rise time/Fall time control
- Equipped with RS232C and USB Interface



An ideal AC Hipot Tester with ownership realized, built on 50 years of experience!

Rise/Fall Time control function of the applied voltage

*Equipped with a Rise time/
Fall time control function*

Prevents from an excessive stress applied to the EUT or for standard tests.



Pursuing usability and safety

All new smart design of control panel and output terminals!

Eliminates the projected components of output terminals, and equips with a new type of the LOW terminal. Pursuing the improvement of safety and a convenience in production line, such as providing the protection cover for the front panel.



▲ Output terminal
Left: HIGH (red)
Right: LOW
(black, with lock function)

Highly stable output

*Newly developed, high-efficiency
PWM switching amplifier!*

Providing a stable output of high voltage without being affected by AC line variation. Ensure the user to perform highly reliable testing with confidence, even in regions with large voltage variations. (Input voltage fluctuation rate: $\pm 0.3\%$)

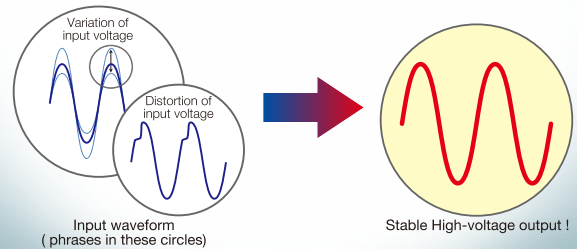

Reducing the tact time

Increasing the productivity!

Capable of setting the test time from 0.1 s

low cost of more than

More than 50 years of experience to support "JAPAN-quality"

Our electronic safety tester has more than 50 years of history since the first product was released in 60's.

High Precision High Resolution

*± 1.5 % of reading**

High-precision measurement ±1.5 % of reading *(with voltmeter 500 V or higher, Ammeter 1 mA or higher)

Supporting the World-wide input voltage

Universal usability!

Usable in any country without changing the input power supply.

Selectable output frequency!

Not rely on the input power environment. It supplies the stable test voltage with 50/60 Hz frequencies.





AC Hipot Tester | TOS5200

TOS5200 is designed for AC Hipot Test with 500 VA capacity and 200 mA short circuit current output capability. Equipped with the PWM amplifier, the TOS5200 can provide a stable & reliable output without being affected by AC power line. Therefore, it is a perfect solution for electronic equipment or devices complied to IEC, EN, UL, VDE and JIS etc. requirement. As TOS5200 covers most of features of our upper class model for AC Hipot Test, it achieves the superb cost / performance ratio for those who need 200 VA or 500 VA capacity, or both. Also, as it equips the Interlock function together with other safety features, operator can carry out the test with higher current value in safe.



The TOS5200 has many improvements from the predecessor !

Specification comparison item		TOS5200	TOS5050A
Test voltage	Output method	PWM switching amp system	Slide transformer method
	Distortion	3 % or less	As per commercial power supply waveform
	Frequency	50 Hz or 60 Hz	Synchronized with commercial power supply waveform
	Output voltage waveform	Sine	Commercial power supply waveform
	Voltage regulation	10 % or less	15 % or less
	Input voltage variation	±0.3 %	-
Test time	Minimum setting value	0.1 s	0.5 s
	Accuracy	±(100 ppm + 20 ms) excluding Fall Time	±(100 ppm + 20 ms)
Judgment feature	Upper limit setting	AC: 0.01 mA to 110 mA	AC: 0.1 mA to 110 mA
	Lower limit setting	AC: 0.01 mA to 110 mA	AC: 0.1 mA to 110 mA
	Accuracy	1.00 mA ≤ i: ±(1.5 % of set), i < 1.00 mA: ±(1.5 % of set + 30 μA)	Upper limit: ±(5 % + 20 μA)
	Rise Time and Fall Time control features	3	-
Voltmeter	Display	Digital	Digital, analog
	Measurement accuracy	±1.5 % of reading (V>500V)	±1.5 % f.s
Voltmeter/Ammeter	Measurement method	True rms/mean-value	Mean-value/rms value
RS232C Interface		POWER Switch and all function except Key lock	Output for data, test result
Weight		Approx. 14 kg (30.9 lbs)	Approx. 15 kg (33.07 lbs)
Other	Input power supply	100 Vac to 240 Vac	100 V ± 10 %
Appearance			



Highly stable output is realized with PWM Switching Amplifier!

Equipped with the PWM switching amplifier system, **the TOS5200 realizes highly stable output without influenced by input form AC line.**

A conventional Hipot Tester boosts and outputs the AC line's input voltage through the use of a slide transformer system. With this slide transformer system, input voltage fluctuations will affect the output, preventing test from being performed properly. Since the TOS5200 equips with a high-efficient PWM amplifier that can output a stable high-voltage without being affected by the variation of AC power line, users can perform "safe", "stable", and highly "reliable" tests with confidence, even in regions with large voltage variations.

The output waveform is essential factor in Hipot (Withstanding oltage) testing!

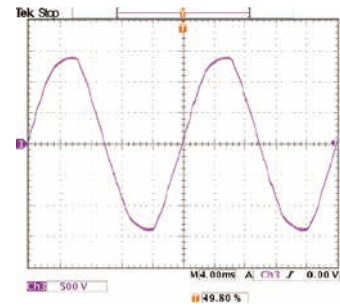
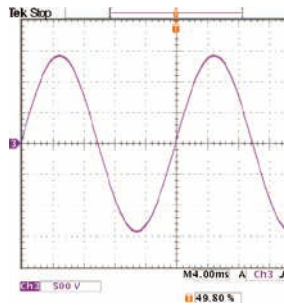

High-Accuracy = Less measurement error! "+/-1.5 % of reading" versus "+/-1.5 % f.s."

TOS5200 ▶ reading: Accuracy is specified against reading value.

TOS5050A ▶ f.s: Accuracy is specified against full scale.

When using TOS5200 at 1500 V output measurement, the max error would be 1500 V(reading value) x 1.5 % = 22.5 V

On the other hand, when using equipment which specifies its accuracy with "+/- 1.5 % f.s.",

the max error could be 2500 V(max voltage) x 1.5 % =37.5 V (it needs to set the range 0 to 2.5 kV)

So, there is 15 V difference of max measurement error at 1500 V output.



Capable of Test Time setting from 0.1 s, which enables to reduce the tact time !

TOS5200 can set the test time from 0.1 sec without sacrificing measurement accuracy.

This makes test time 5 times faster compared to the TOS5050A (max test time:0.5sec) and it leads to reduce the tact time.

Reduction of the tact time leads to improve the productivity, so it has been an issue that reducing the tact time may cause to worsen the measurement accuracy when the test time is faster than measurement respond speed.

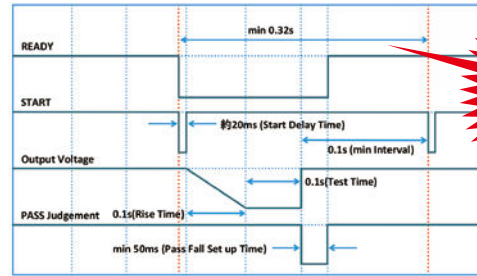

Cycle time
minimize to
0.32 s



Rise time / Fall time control function

The rise time control function is **to prevent the excessive stress that is being applied to the EUT (test object)**. The Hipot (Withstanding voltage) test is conducted to verify the safety performance of the EUT and which test voltage for Hipot (Withstanding voltage) test is applied approximately five to ten times greater than the voltage that handles by the EUT. If a high voltage is applied rapidly with no rise time, the transitional large voltage (current) will be occurred, and it may cause a damage to the EUT. For this reason, safety standards stipulate the procedure of Hipot (Withstanding voltage) test, and the test voltage must be gradually increased to the specified voltage when the test is performed. The rise time control function adopted in the in the TOS5300 Series can set the voltage rise time from 0.1s to 10.0 s (at a resolution of 0.1 s) and also it is capable to set the 50 % (fxed) of the applied test voltage. In addition, the fall time control function enables to decrease the test voltage gradually after the completion of a PASS judgement. The voltage fall time is fxed at 0.1 s (OFF is also selectable).

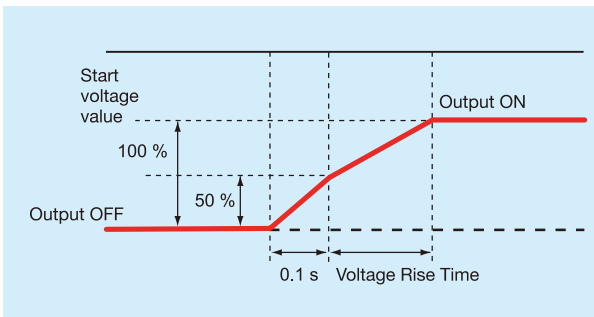

▲Start voltage can be set at 50 % of the test voltage

Rise Time control function

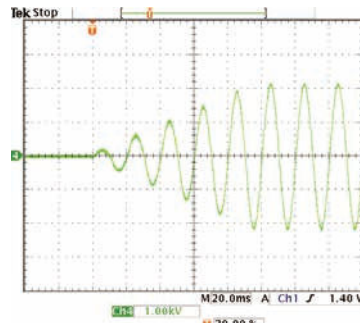

▲Rise time control waveform (example)

The Rise time control function enables you to increases the test voltage gradually to reach the setting voltage while the AC Hipot (Withstanding voltage) test is conducted. The voltage rise time can be set from 0.1 s to 10.0 s at a resolution of 0.1s.

Fall Time control function

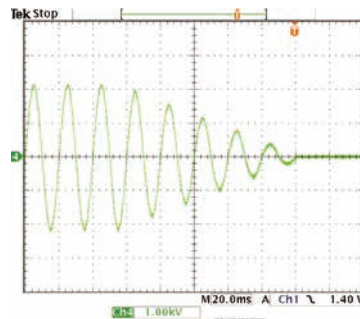

▲Fall time control waveform (example)

The Fall time control function enables you to decrease the test voltage gradually when the PASS judgment is made at the AC Hipot (Withstanding voltage) test. The voltage fall time is fxed at 0.1 s. (OFF is also selectable).



Improved the setting resolution of the leak current by 0.01 mA !

TOS5200 is **can set the current limit from 0.01 mA to 110 mA**. (TOS5050A: 0.1 mA to 110 mA)

- Enable to clarify the actual value of device under test (DUT)
- The setting resolution of the lower limit setting has been improved from the previous model ,it enables to defect the failure more accurately.



Specifications

Unless specified otherwise, the specifications are for the following settings and conditions.

- The warm-up time is 30 minutes.
- TYP: These are typical values. These values do not guarantee the performance of the product.
- rdng: Indicates the readout value. • set: Indicates a setting. • fs: Indicates full scale.

Withstanding voltage tester

AC Output section	Output range		0.05 kV to 5.00 kV				
		Setting accuracy	± (2 % of set + 20 V) [at no load]				
		Setting range	0.00 kV to 5.50 kV				
		Resolution	10 V STEP				
		Max. rated output *1	500 VA (5 kV/100 mA)				
		Max. rated voltage	5 kV				
		Max. rated current	100 mA [output voltage 0.5 kV or higher]				
		Transformer rating	500 VA				
		Output voltage waveform *2	Sine				
		Distortion	If the output voltage is 0.5 kV or more: 3 % or less (when no load or a pure resistive load is connected)				
		Crest factor	Within $\sqrt{2} \pm 3 \%$ (output voltage 800 V or higher, at no load)				
		Frequency	50 Hz or 60 Hz				
		Accuracy	± 0.5 % (excluding during voltage rise time)				
		Voltage regulation	10 % or less (when changing from maximum rated load to no load)				
	Input voltage variation	±0.3 % (5 kV when no load is connected; power supply voltage: 90 V to 250 V)					
	Short-circuit current	200 mA or more (when the output voltage is 1.0 kV or greater)					
	Output method	PWM switching					
Start voltage		The voltage at the start of withstanding voltage tests can be set to 50 % of the test voltage.					
Limit voltage		The test voltage upper limit can be set. AC: 0.00 kV to 5.50 kV					
Output voltage monitor feature		If output voltage exceeds the specified value + 350 V or is lower than the specified value - 350 V, output is turned off, and protective features are activated.					
Voltmeter	Digital	Measurement range	0.000 kV to 6.500 kV AC				
		Display	□.□□□ kV				
		Accuracy	V < 500 V: ± (1.5 % of reading + 20 V), V ≥ 500 V: ±1.5 % of reading				
		Response *3	True rms, Average value response/rms display switchable				
		Hold feature	After a test is finished, the measured voltage is retained until the PASS or FAIL judgment is cleared.				
Ammeter	Digital	Measurement range	0.00 mA to 110 mA				
		Display	i = measured current				
			i < 1 mA	1 mA ≤ i < 10 mA	10 mA ≤ i < 100 mA	100 mA ≤ i	
			□.□□□ mA	□.□□□ mA	□□.□□ mA	□□□.□ mA	
		Accuracy *4	1.00 mA ≤ i: ± (1.5 % of reading), i < 1.00 mA: ± (1.5 % of reading + 30 μA)				
	Response *3	True rms/ Mean-value response rms display Can be switched					
	Hold feature	After a test is finished, the measured current value is retained until the PASS judgment is cleared.					
Judgment feature	Judgment method and judgment operation		Judgment	Judgment method	Display	Buzzer	SIGNAL I/O
			UPPER FAIL	If a current that is greater than or equal to the upper limit is detected, the output is turned off, and an UPPER FAIL judgment occurs.	FAIL LED lights; UPPER is displayed on the screen	ON	Generates a U-FAIL signal
			LOWER FAIL	If a current that is less than or equal to the lower limit is detected, the output is turned off, and a LOWER FAIL judgment occurs. This judgment is not performed during voltage rise time (Rise Time) of all tests and during the voltage fall time (Fall Time) of AC withstanding voltage tests.	FAIL LED lights; LOWER is displayed on the screen	ON	Generates a U-FAIL signal
			PASS	If the specified time elapses without any problems, the output is turned off, and a PASS judgment occurs.	PASS LED lights; displayed on the screen	ON	Generates a PASS signal
	<ul style="list-style-type: none"> • If PASS HOLD is enabled, the PASS signal is generated continuously until the TOS5300 Series receives a STOP signal. • The UPPER FAIL and LOWER FAIL signals are generated continuously until the TOS5300 Series receives a STOP signal. • The FAIL and PASS buzzer volume levels can be changed. • For PASS judgments, the length of time that the buzzer sounds for is fixed to 0.2 seconds. Even if PASS HOLD is enabled, the buzzer turns off after 0.2 seconds. 						
	Upper limit setting		0.01 mA to 110 mA				
	Lower limit setting		0.01 mA to 110 mA / OFF				
	Judgment accuracy *4		1.00 mA ≤ i: ± (1.5 % of set), i < 1.00 mA: ± (1.5 % of set + 30 μA)				
	Current detection method		Calculates the current's true rms value and compares this value with the reference value				
	Calibration		Calibrated with the rms of a sine wave using a pure resistive load				
Time	Voltage rise time		0.1 s to 10.0 s				
		Resolution	0.1 s				
	Voltage fall time		0.1 s / OFF (only enabled when a PASS judgment occurs)				
	Test Time		0.1 s to 999 s, can be turned off (TIMER OFF)				
		Resolution	0.1 s to 99.9 s: 0.1 s/100 s to 999 s: 1 s				
Accuracy		±(100 ppm + 20 ms) excluding Fall Time					

Specifications

***1. Regarding the output time limits:**

Taking size, weight, and cost into consideration, the heat dissipation capability of the voltage generator that is used for withstanding voltage tests has been designed to be one half that of the rated output. Use the TOS5300 Series within the following limits. If you use the product in a manner that exceeds these limits, the output section may overheat, and the internal protection circuits may be activated. If this happens, stop testing, and wait until the TOS5300 Series returns to its normal temperature.

Ambient temperature	Pause time	Output time
t ≤ 40 °C	50 mA < i ≤ 110 mA	Greater than or equal to the output time
	i ≤ 50 mA	Not necessary
		30 min. max.
		Continuous output possible

(Output time = voltage rise time + test time + voltage fall time)

***2. Regarding the test voltage waveform:**

Waveform distortions may occur if an DUT whose capacitance is dependent on voltage (for example, an DUT that consists of ceramic capacitors) is connected as the load. However, if the test voltage is 1.5 kV, the effect of a capacitance of 1000 pF or less can be ignored. Because the product's high-voltage power supply uses the PWM switching method, if the test voltage is 500 V or less, the switching and spike noise proportions are large. The lower the test voltage, the greater the waveform is distorted.

***3. For both True rms and Mean-value response, 50 ms or above response time is required to satisfy the measurement accuracy.**

***4. Regarding ammeter and judgment accuracy:**

During AC withstanding voltage tests, current also flows in the stray capacitance of items such as the measurement leads and jigs. This current that flows in the stray capacitances is added to the current that flows in the DUT, and the sum of these currents is measured. Especially if you want to perform judgments with high sensitivity and accuracy, it is necessary to consider methods to limit the current that flows in these stray capacitances, such as by adding upper and lower limits.

Output voltage	1 kV	2 kV	5 kV
When using 350 mm long test leads that are suspended in air (TYP)	2 μA	4 μA	10 μA
When using the accessory, high test lead TL31-TOS (TYP)	16 μA	32 μA	80 μA

In case of 70 % humidity or higher, it is considerable to add 50 μA on the Limit value.

Other features / Interfaces

Test mode		
Double action feature		Tests can only be started by pressing and releasing STOP and then pressing START within 0.5 seconds of releasing the STOP switch.
Length of time to maintain a PASS judgment result		You can set the length of time to maintain a PASS judgment: 50 ms, 100 ms, 200 ms, 1 s, 2 s, 5 s, or HOLD.
Momentary feature		Tests are only executed while the START switch is held down.
Fail mode feature		This feature enables you to prevent remotely transmitted stop signals from clearing FAIL judgments and PROTECTION modes.
Timer feature		This feature finishes tests when the specified time elapses.
Output voltage monitor feature		If output voltage exceeds "setting + 350 V" or is lower than "setting - 350 V," the TOS5200 switches to PROTECTION mode, output is turned off, and testing finishes.
Memory		Up to three sets of test conditions can be saved to memory.
Key lock		Locks panel key operations (settings and changes).
Protective features		
Interlock Protection		An interlock signal has been detected.
Power Supply Protection		An error was detected in the power supply.
Volt Error Protection		While monitoring the output voltage, a voltage outside of the rated limits was detected. AC or DC withstanding voltage tests: ±350 V
Over Load Protection		During a withstanding voltage test, a value that is greater than or equal to the output limit power was specified. AC withstanding voltage test: 550 VA.
Over Heat Protection		The internal temperature of the TOS5200 became too high.
Over Rating Protection		During a withstanding voltage test, the output current was generated for a length of time that exceeds the regulated time.
Remote Protection		A connection to or disconnection from the front-panel REMOTE connector was detected.
SIGNAL I/O Protection		The rear-panel SIGNAL I/O connector's ENABLE signal has changed.
USB Protection		The USB connector has been disconnected while the TOS5200 was being controlled through the USB interface.
Interfaces		
USB		USB Specification 2.0
RS232C *1		D-SUB 9-pin connector on the rear panel (compliant with EIA-232-D) All functions other than the POWER switch and KEY-LOCK
REMOTE		Front-panel 9-pin MINI DIN connector. By connecting an optional device to this connector, you can control the starting and stopping of tests remotely.
SIGNAL I/O		Rear-panel D-sub 25-pin connector

*1. "Talk mode" can be set, when RS232C is used as communication interface.

Talk mode	Description	
0	It responds only for commands from PC. (Default setting)	
1	It responds automatically for start and end test, and returns the status, setting value, measured value.	
	Response at start	<START>
	Response at end of test	Status Setting value, Measured value <PASS>, <U_FAIL>, <L_FAIL>, <PROT>, <ABOUT> Test No., Programme No., Test mode, Measured voltage, Measured current, Test time

■ Specifications

■ General

Display		LCD: LED back custom indicators	
Environment	Installation location		Indoors, at a height of up to 2000 m
	Spec guaranteed range temperature/humidity		5 °C to 35 °C (41 °F to 95 °F)/20 %rh to 80 %rh (no condensation)
	Operating range temperature/humidity		0 °C to 40 °C (32 °F to 104 °F)/20 %rh to 80 %rh (no condensation)
	Storage range temperature/humidity		-20 °C to 70 °C (-4 °F to 158 °F)/90 %rh or less (no condensation)
Power supply	Nominal voltage range (allowable voltage range)		100 VAC to 240 VAC (90 VAC to 250 VAC)
	Power consumption	When no load is connected (READY)	100 VA or less
		When rated load is connected	800 VA max.
	Allowable frequency range		47 Hz to 63 Hz
Insulation resistance (between AC LINE and the chassis)		30 MΩ or more (500 VDC)	
Withstanding voltage (between AC LINE and the chassis)		1500 Vac, 1 minute	
Earth continuity		25 Aac, 0.1 Ω or less	
Electromagnetic compatibility (EMC) *1 *2		Complies with the requirements of the following directive and standards. EMC Directive 2014/30/EU EN 61326-1(Class A *3), EN 55011(Class A *3, Group 1 *4), EN 61000-3-2, EN 61000-3-3 Applicable under the following conditions. The maximum length of all cabling and wiring connected to the TOS5200 is less than 2.5 m. Shielded cables are being used when using the SIGNAL I/O. The high-voltage test lead TL31-TOS is being used. Electrical discharges are not occurring outside the DUT.	
Safety *1		Complies with the requirements of the following directive and standard. Low Voltage Directive 2014/35/EU *2, EN 61010-1 (Class I *5 Pollution degree 2 *6)	
Dimensions (mm(inches))(maximum)		320 (12.6") (330(12.99")) W × 132(5.2") (150(5.91")) H × 350(13.78") (420(16.54")) D	
Weight		Approx. 14 kg (30.9 lbs)	
Accessories		Power cord : 1pc. / High test lead (TL31-TOS) : 1set (1 red wire and 1 black wire, each with alligator clips); 1.5 m / SIGNAL I/O plug : 1 set (assembly type) / High-voltage warning sticker : 1pc. / Setup Guide / Quick Reference(1 each for English and Japanese) / Safety information / CD-R	

*1 Does not apply to specially ordered or modified TOS5200s.

*2 Limited to products that have the CE mark on their panels. Not be in compliance with EMC limits unless the ferrite core is attached on the cable for connection of J1 connector.

*3 This is a Class A equipment. The TOS5200 is intended for use in an industrial environment. This product may cause interference if used in residential areas. Such use must be avoided unless the user takes special measures to reduce electromagnetic emissions to prevent interference to the reception of radio and television broadcasts.

*4 This is a Group 1 equipment. The TOS5200 does not generate and/or use intentionally radio-frequency energy, in the form of electromagnetic radiation, inductive and/or capacitive coupling, for the treatment of material or inspection/analysis purpose.

*5 This is a Class I equipment. Be sure to ground the TOS5200's protective conductor terminal. The safety of this product is only guaranteed when the product is properly grounded.

*6 Pollution is addition of foreign matter (solid, liquid or gaseous) that may produce a reduction of dielectric strength or surface resistivity. Pollution Degree 2 assumes that only non-conductive pollution will occur except for an occasional temporary conductivity caused by condensation.

■ Outline drawing

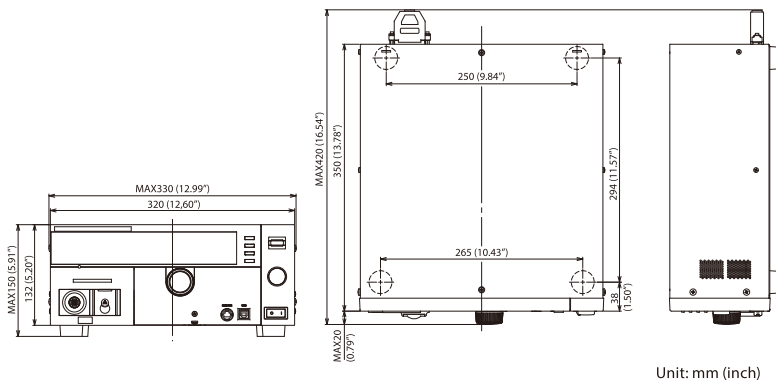

TU01-TOS

Option(s) for Electrical Safety Testers

The TU01-TOS is a terminal unit that converts the 25 pin SIGNAL I/O connector of the Kikusui TOS5200 Withstanding Voltage Tester to the 14 pin SIGNAL I/O connector of the TOS5050A/ 5051A. You can insert this unit between a controller and a TOS5200 to perform the same external control that you can perform on the TOS5050A/ 5051A.



KIKUSUI ELECTRONICS CORPORATION

Southwood 4F,6-1 Chigasaki-chuo,Tsuzuki-ku,Yokohama,224-0032,Japan
Phone: (+81)45-482-6353,Facsimile: (+81)45-482-6261,www.kikusui.co.jp

KIKUSUI AMERICA, INC. 1-310-214-0000 www.kikusuiamerica.com



3625 Del Amo Blvd, Suite 160, Torrance, CA 90503
Phone : 310-214-0000 Facsimile : 310-214-0014

KIKUSUI TRADING (SHANGHAI) Co., Ltd. www.kikusui.cn



Room 305,Shenggao Building ,No.137,Xianxia Road, Shanghai City, China
Phone : 021-5887-9067 Facsimile : 021-5887-9069

For our local sales distributors and representatives, please refer to "sales network" of our website.

Printed in Japan

●Distributor/Representative

For more information



dhs ELMEA tools GmbH

Rudolf-Diesel-Straße 2B
63322 Rödermark / Germany

Tel. +49 60 74 91 9908-0
web dhs-tools.de
mail info@dhs-tools.de

■ All products contained in this catalogue are equipment and devices that are premised on use under the supervision of qualified personnel, and are not designed or produced for home-use or use by general consumers.

Issue:Oct.2019 201910PDFEC21a